



Performance package in the compact class

CityCat 5006

CityCat 5006: performance package in the compact class

The CityCat 5006 compact street sweeper sets a new standard for compact sweepers with its unique design and pioneering technology. Power is supplied by a potent 118kilowatt diesel engine with AdBlue additive and an exhaust after-treatment system which allows the CityCat 5006 to meet the strict Euro 6c emissions standard.

The whole package sets standards for performance and range with its high suction power, large hopper and a huge water storage capacity.

The machine provides staff with a high degree of driving and operating comfort. The spacious cabin, optionally available with three seats, has large windows to provide a clear view forward and of the side brushes.

The compact outer dimensions, as well as the four-wheel steering that can be turned on and off, give the vehicle maximum manoeuvrability and ensure perfect directional stability and safety for everyday work.

Whether on the motorway, main roads or side streets, in city centres, Pedestrian zones, at bus stops, in narrow passageways or rest areas: the CityCat 5006 can be used in a huge variety of places.



Outstanding sweeper performance

The CityCat 5006 sweeper combines high suction performance and range with environmentally friendly operation. The superior performance and range of this compact unit from Bucher Municipal sets the standard for the 5 m³ class.



Effective winter service The CityCat 5006 is suitable for both effective snow clearance and a balanced approach to dealing with icy and snow-covered roads. It efficiently clears commercial and shipment areas, paths and streets as well as access routes and car parks.



Speed 80 km/h The 5 m³ compact CityCat 5006 street sweeper is also available in an 80 km/h variant. This allows it to travel and sweep on motorways and other fast stretches of road.

CityCat 5006: the economical year-round machine

The CityCat 5006 can be converted from sweeping to winter operation in record time. Straight from the factory, the CityCat 5006 comes ready for winter service: for example, the flexible subframe under the hopper allows retrofitting the CityCat 5006 for (grit and de-icer) spreading duties. A well-thought-out clutch system allows all hydraulic and electric cabling to be decoupled in no time at all, so the driver can modify the sweeper for winter conditions, unassisted, in only 30 minutes. In this configuration, the sweep gear and suction nozzle simply remain on the sweeper.

For snow-clearing service and de-icing, the Bucher Municipal CityCat 5006 features a snow plough, which is mounted on the same mounting plate as the front brush and controlled by the front brush joystick. Also available: a spreader (1.8 m³) that can handle wet salt. Drivers and fleet managers can review cleaning and spreading hours, or even transfer these onto a USB stick and analyse the data at a PC.

The innovative features of the CityCat 5006 make it an economical year-round machine.



CityCat 5006 technical data

Dimensions

| | |
|---------------------|---------|
| Length | 4945 mm |
| Width | 1798 mm |
| Height | 2500 mm |
| Wheelbase | 2450 mm |
| Track | 1513 mm |
| Max. sweeping width | |
| 2 brushes | 2533 mm |
| 3 brushes | 3520 mm |
| 3 brushes RCB | 3768 mm |
| Turning radius | 2950 mm |

Chassis

| | |
|-------------|------------------------------|
| GVW | 10500 kg / 10400 kg (80km/h) |
| Kerb weight | 5500 kg / 5600 kg (80km/h) |
| Payload | 5000 kg / 4900 kg (80km/h) |

Motor

| | |
|--------------------------------|---|
| FPT, Iveco Euro 6c | NEF4 Euro VI Step C |
| FPT, Iveco Stage IIIV / Tier 3 | NEF4 Stage III A |
| Displacement | 4485 cm ³ |
| Power | 118 kW / 104 kW |
| Torque | 580 Nm (Euro 6c) 608 Nm (Stage III A / Tier 3) |
| Fuel tank | 110 l |
| AdBlue-Tank (Euro 6c only) | 30 l |
| Electrical system | 24 V |

Performance

| | |
|--------------------|-------------|
| Working speed | 0 – 20 km/h |
| Travelling speed | 0 – 80 km/h |
| Gradeability up to | 30% |

Hopper

| | |
|------------------------------|---------|
| Discharge height | 930 mm |
| Discharge height (high dump) | 1550 mm |
| Discharge width | 1700 mm |
| Discharge angle | 51° |
| AdBlue-Tank (Euro 6c only) | 30 l |
| Electrical system | 24 V |

Water system

| | |
|----------------------------|--|
| Water capacity | 880 l |
| High-pressure water system | 100 bar @ 30 l/min 20 bar @ 120 l/min 200 bar @ 15 l/min |

Suction system

| | |
|-------------------------|-----------------|
| Suction nozzle width | 800 mm |
| Suction nozzle material | Stainless steel |
| Wander hose | Ø 250 mm |

General

| | |
|-------------------|----------------------------|
| Tyres | 265 / 70 R 19.5 140 / 138M |
| Cabin noise level | 63 dB(A) |

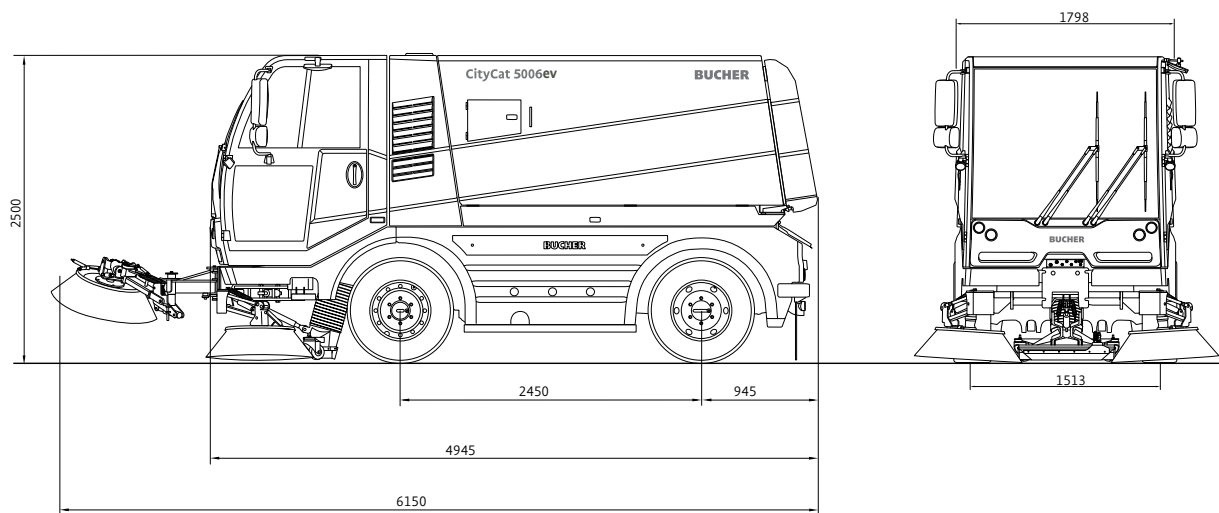

CityCat 5006 technical description

Steering Hydrostatic-controlled fourwheel steering with hydraulic servo support, 80 km/h mechanical variant.

Axles Drive axle at the rear with differential and planetary hub reduction. Running axle at the front.

Brakes Hydraulic, dual-circuit high-performance brake system with double callipers on each side on front axis and single calliper on rear axis. Manually operated parking brake, acting hydraulically on additional brake disc in front of differential.

Driver's cab Comfortable, hydro bearing suspension, soundproofed cab. Windscreen made of heat-insulating, curved, low-reflection safety glass. Two sliding windows in each door. Multi-speed heating fan. Sun visor. Windscreen wiper/washer system. Air-sprung driver's seat and sprung passenger's seat, each individually adjustable. Steering column can be adjusted in both angle and height. Clearly and ergonomically arranged operating and monitoring instruments with a 7-inch colour display. Visual and acoustic alarm for temperature and liquid level monitoring. Visual diagnostic system with intuitive design.

Sweeping system Pick-up principle based on suction, with retracted, rust-proof suction nozzle in front of axis, can be hydraulically moved 400 mm laterally with the side brush. Hydraulic suction nozzle height adjustment. Stepless adjustable high-power suction fan.

Water
Water capacity approx. 880 l
Two water pumps for the water nozzles.

Brushes
Two side brushes left and right Ø 900 mm
Variable speed adjustment 0–150 rpm
Impact-proof brush suspension-impact protection.

A third brush for a maximum cleaning width of 3768 mm and for sweeping corners and ramps; can be used left, right, centred and on a second raised level.

Chassis Ladder frame chassis with a C-profile structure from Bucher Municipal

Vehicle drive
Drive axle rear
System manufacturer Bosch-Rexroth
Drive system hydrostatisch / stufenlos

Options

- Driving speed 80 km/h
- Road construction brush
- Additional water tank 1120 l (total 2000 l)
- Boom with reel and hand lance
- Air conditioning
- High dump
- Water recirculation system
- Wander hose
- Weed brush
- Hydraulic tilt of the side brushes
- High-pressure water system
- EasyClean system
- Hydraulic mesh lifting system
- Leaf grid lifter
- LED working lights
- Rear-view and suction nozzle camera
- Data capture
- A variety of winter maintenance options

A wide range of further options are available – please contact us for more information.

Technical data are subject to change without prior notice.



Boom with reel and hand lance Two booms are mounted on the hopper with a reel and a hand lance that are connected to the highpressure water system of the CityCat 5006. These are useful for flushing rubbish from the sides of the street directly in front of the sweeper to significantly increase the working width and efficiency.



Additional 1120-litre water tank The additional 1120-litre water tank increases the total capacity to 2000-litres, thus maximising operating time. This enables simultaneous washing and sweeping.



Road construction brush The robust brush is particularly suited for heavy use on road construction sites and weed removal applications. It provides a large working area and even better coverage in curves. Furthermore, it has a ground pressure control and a bidirectional tilt adjustment.

Bucher Municipal AG

Murzlenstrasse 80
CH-8166 Niederweningen
Tel. +41 44 857 22 11
Fax +41 44 857 24 10
sweepers@buchermunicipal.com
www.buchermunicipal.com/sweepers

Bucher Municipal Ltd.

258 Seohaean-ro
Siheung-si, Gyeonggi-do
Korea (15086)
Tel. +82 31 498 89 61-3
Fax +82 31 498 89 85
info@buchermunicipal.co.kr
www.buchermunicipal.co.kr

Bucher Municipal GmbH

Schörlingstrasse 3
DE-30453 Hannover
Tel. +49 511 214 90
Fax +49 511 214 9 - 115
sweepers.de@buchermunicipal.com
www.buchermunicipal.com/sweepers

www.buchermunicipal.com/sweepers

Your Bucher Municipal contractual partner:

